

X5

Snap-action Microswitches

Ultraminiature

SICATRON
elektronik & automation

SICATRON OHG
Pettenkoferstr. 19
58097 Hagen, Germany

Fon +49 (0) 2331 473329-0
Fax +49 (0) 2331 473329 200
<http://www.sicatron.de> info@sicatron.de

X5

Characteristics	<ul style="list-style-type: none">■ small size■ low current■ PCB mounting
Rating	250 VAC, 1.5 A
Dimensions (mm)	13 × 6.5 × 6
Actuator	<ul style="list-style-type: none">■ plunger■ plain lever
Approvals	UL, CSA



Preferred Range

Ordering Reference	Actuating Force (N)	Sealing	Operating Position (mm)	Terminal	Circuit	Actuator	Contacts	Electrical Rating
X5G303K1AN	1.5	IP40	5.5	PCB	CO	Plunger	Ag	250 VAC, 1.5 A, 125 VAC, 3 A
X5G303K1ANJ1	0.5	IP40	7.2	PCB	CO	Lever	Ag	250 VAC, 1.5 A, 125 VAC, 3 A

Specifications

Housing	Thermoplastic
Plunger	Thermoplastic
Mechanism	Snap-action system with steel tension spring functions
Contacts	Silver
Terminals	PCB
Temperature range °C	75° C
Mechanical life	5–10 ⁵ cycles minimum
Protection	IP40 (enclosure)
Mounting	PCB, Side mounting
Actuators	Plunger, lever
Contact carrier	Brass

Circuit diagram

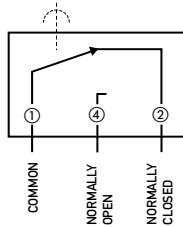

Dimensions

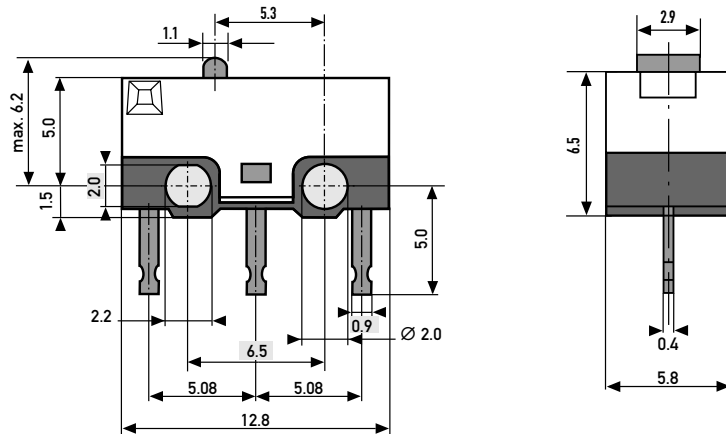

Recommended maximum electrical ratings

Voltage (VAC)	Resistive load (A)
125	3
250	1.5

Operating Characteristics

Actuator	Reference	Actuating Force Maximum		Release Force Minimum		Free Position Maximum		Operating Position		Movement Differential		Full Overtravel Position	
		(N)	(ozf)	(N)	(ozf)	(mm)	(in)	(mm)	(in)	(mm)	(in)	(mm)	(in)
Plunger	X5G3	1.5	5.35	0.2	0.72	6.2	0.24	5.5 ± 0.3	0.22 ± 0.01	0.2	0.008	5	0.2

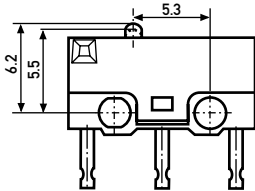

J-Lever	X5G3...J1	0.5	1.80	0.05	0.18	9.5	0.37	7.2 ± 1.5	0.28 ± 0.06	0.8	0.032	5.3	0.21
---------	-----------	-----	------	------	------	-----	------	-----------	-------------	-----	-------	-----	------

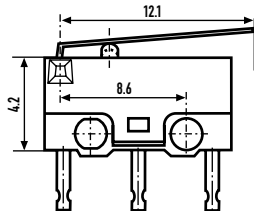

Width of lever 3.6 mm/0.14 in

Type coding key for standard products

Basic type	X5	Example: X5 G 3 03 K 1 A J0											
Operating force	G	Standard	Fs max. 150 cN										
Circuit diagram	3	Change-over											
Terminals	03	PCB, vertical											
	10	PCB, Formed to the left = view from lever											
	11	PCB, Formed to the right = view from lever											
Body/ moving system	K	Material	Thermoplastic	moving system									
		lid:	PC black										
		base:	PA 66 GF 25 copperbrown	A									
	M	lid:	PA 66 GF 25 copperbrown										
		base:	PA 66 GF 25 copperbrown	A									
	N	lid:	PC black										
		base:	PA 66 GF 25 copperbrown	E									
	P	lid:	PA 66 GF 25 copperbrown										
		base:	PA 66 GF 25 copperbrown	E									
Contacts material	1	Ag / Ag											
	8	Gold Microprofile (Crossbar-contact)											
UL/cUL/CSA ratings	A	1.5 A, 250 VAC approved											
		3.0 A, 125 VAC approved											
	N	No approved											
Type of actuator		No symbol, without lever											
	J0 to J9	Straight lever											
	L0 to L9	Cam follower											
	M0 to M9	Formed lever											